



VI-ARM™

Autoranging Rectifier Modules

Up to 1500 Watts

Features

- Autoranging input
- Microprocessor controlled
- *VI-ARM-C1*
500 Watts @ 90-132Vac
750 Watts @ 180-264Vac
- *VI-ARM-C2*
1000 Watts @ 90-132Vac
1500 Watts @ 180-264Vac
- 96-98% Efficiency
- 100°C baseplate (no derating)
- UL, CSA, TÜV, VDE, BABT
- AC Bus OK, module enable
- Inrush limiting (no external circuitry)
- CE Marked

Typical Applications: systems requiring a rugged, full featured interface to the AC mains in the smallest possible package.

Product Highlights

The ARM (Autoranging Rectifier Module) is an AC front end module which provides autoranging line rectification and inrush current limiting. The ARM is available in either 500/750W or 750/1000W models in a mini sized package measuring only 2.28" x 1.45" x 0.5".

The ARM interfaces directly with worldwide AC mains and may be used with Vicor 1st or 2nd Generation 300V input DC-DC converters to realize an autoranging, high density, low profile switching power supply. The ARM includes a microcontroller that continuously monitors the AC line to control bridge/doubler operation. The user need only provide external capacitance to satisfy system hold-up requirements.

Vicor 2nd Generation packaging technology offers flexible mounting options for various manufacturing processes. The ARM may be installed as a conventional leaded device for on-board applications, in-board for low profile, height restricted applications, socketed or surface mounted with optional ModuMate interconnect products.



Actual size:
2.28 x 1.45 x 0.5 in
57,9 x 36,8 x 12,7 mm

Absolute Maximum Ratings

Parameter	Rating		Notes
	VI-ARM-1/VI-ARM-2	Unit	
L to N	264	Vac	
L to N	280	Vac	100ms
+Out to -Out	400	Vdc	
B OK to -Out	16	Vdc	
EN to -Out	16	Vdc	
Output power	500/1000	Watts	90-132Vac
	750/1500	Watts	180-264Vac
Mounting torque	4 - 6 (0.45 - 0.68)	in- lbs (N-m)	6 each, 4-40 screw
Pin soldering temperature	500 (260)	°F (°C)	<5 sec; wave solder
Pin soldering temperature	750 (390)	°F (°C)	<7 sec; hand solder
Storage temperature (C, T-Grade)	-40 to +125	°C	
Storage temperature (H-Grade)	-55 to +125	°C	
Storage temperature (M-Grade)	-65 to +125	°C	
Operating temperature (C-Grade)	-20 to +100	°C	Baseplate
Operating temperature (T, H-Grade)	-40 to +100	°C	Baseplate
Operating temperature (M-Grade)	-55 to +100	°C	Baseplate

Thermal Resistance and Capacity

Parameter	Typ	Unit
Baseplate to sink; flat, greased surface	0.24	°C/Watt
Baseplate to sink; with thermal pad (P/N 16495)	0.3	°C/Watt
Baseplate to ambient- free convection	15	°C/Watt
Baseplate to ambient; 1000 LFM- forced air	2.7	°C/Watt
Thermal capacity	48	Watt-sec/°C

Part Numbering

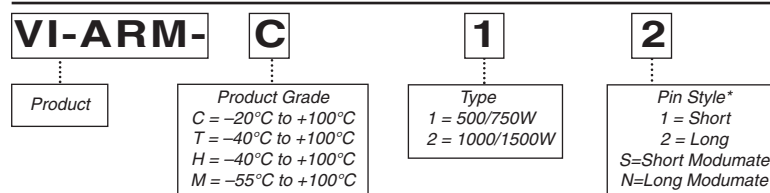

*Pin styles S & N are compatible with the ModuMate interconnect system for socketing and surface mounting.

Electrical Characteristics

Electrical characteristics apply over the full operating range of input voltage, output load (resistive) and baseplate temperature, unless otherwise specified. All temperatures refer to the operating temperature at the center of the baseplate. Specifications apply for AC mains having up to 5% total harmonic distortion.

MODULE INPUT SPECIFICATIONS

Parameter	VI-ARM - 1			VI-ARM - 2			Unit	Notes
	Min	Typ	Max	Min	Typ	Max		
Operating input voltage	90		132	90		132	Vac	Autoranging (doubler mode)
Operating input voltage	180		264	180		264	Vac	Autoranging (bridge mode)
Input undervoltage			90			90	Vac	No damage
Input surge withstand			280			280	Vac	100ms
AC line frequency	47		63	47		63	Hz	C-Grade
AC line frequency	47		880	47		880	Hz	T, H & M Grade
Input current, rms	0		7.4	0		14.8	Amps	120Vac
Input current, rms	0		5.4	0		10.8	Amps	240Vac
Power factor	0.60			0.60				Typical line voltage condition
Inrush current			30			60	Amps	264Vac peak line, cold start
Holdup capacitance			1600			3300	µF	

MODULE OUTPUT SPECIFICATIONS

Parameter	VI-ARM - 1			VI-ARM - 2			Unit	Notes
	Min	Typ	Max	Min	Typ	Max		
Output power	0		500	0		1000	Watts	90-132Vac
Output power	0		750	0		1500	Watts	180-264Vac
Efficiency, 120Vac	94	96		94	96		%	
Efficiency, 240Vac	96	98		96	98		%	
Output voltage	200		375	200		375	Vdc	90-264Vac

SAFETY SPECIFICATIONS

Parameter	Min	Typ	Max	Unit	Notes
Agency approvals					UL 1950, CSA 22.2 No. 950, TÜV, VDE, EN60950, CE Marked
Isolation voltage (in to out)	None				Isolation provided by DC-DC converter(s)
Isolation voltage (I/O to baseplate)	1500			Volts, rms	
Leakage current			100	µA	No filter

Electrical Characteristics, continued

■ MODULE CONTROL SPECIFICATIONS

Parameter	Min	Typ	Max	Unit	Notes
AC Bus OK (B OK)					
On-state resistance (low)			15	Ω	To negative output - bus normal
On-state current (low)			-50	mA	Bus normal
Off-state voltage	14.8	15.0	15.2	Vdc	Bus abnormal, 27K internal pull up to 15Vdc (Fig. 10)
On-state threshold	235	240	245	Vdc	Output bus voltage
Off-state threshold	200	205	210	Vdc	Output bus voltage
Module Enable (EN)					
On-state resistance (low)			15	Ω	To negative output - converters are disabled
On-state current (low)			50	mA	
Off-state voltage	14.8	15.0	15.2	Vdc	150K internal pull up to 15Vdc (Fig. 9)
On-state threshold	235	240	245	Vdc	Output bus voltage
Off-state threshold	200	205	210	Vdc	Output bus voltage
Over voltage shutdown	380	390	400	Vdc	
AC Bus OK - module enable, differential error*	15	17	20	Vdc	AC Bus OK and module enable thresholds track

* Tracking error between BUS OK and Enable thresholds

■ MODULE GENERAL SPECIFICATIONS

Parameter	Min	Typ	Max	Unit	Notes
MTBF		>1,000,000		hours	25°C, ground benign
Baseplate material					Aluminum
Cover					Polyetherimide
Pin material					Copper, tin/lead solder dipped
Weight		2.1 (60)		ounces (grams)	
Size		2.28 x 1.45 x 0.5 (57,9 x 36,8 x 12,7)		inches (mm)	

Operating Characteristics

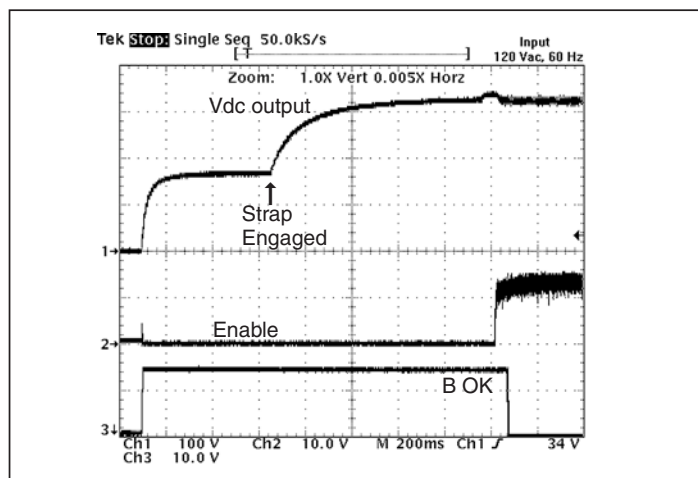

Figure 1—Start-up at 120Vac input

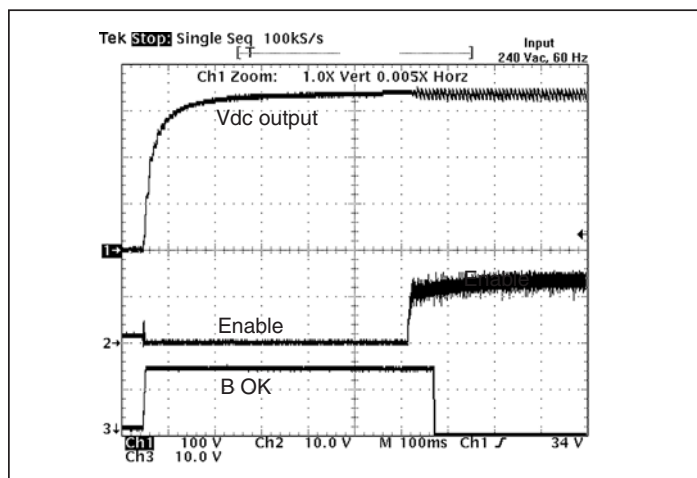

Figure 2—Start-up at 240Vac input

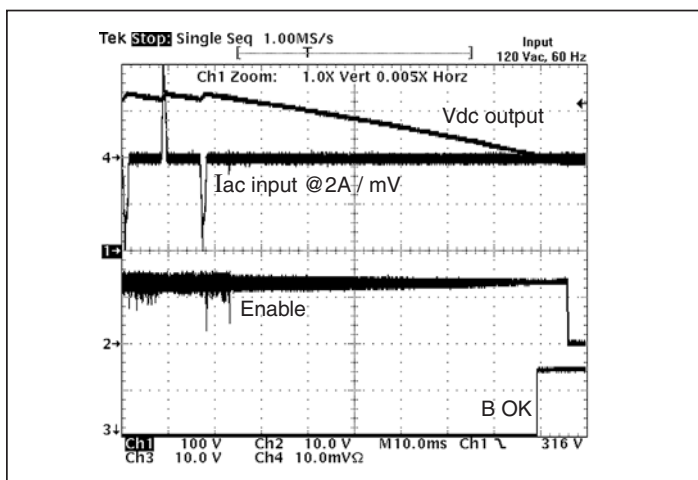

Figure 3—Power down, from 120Vac

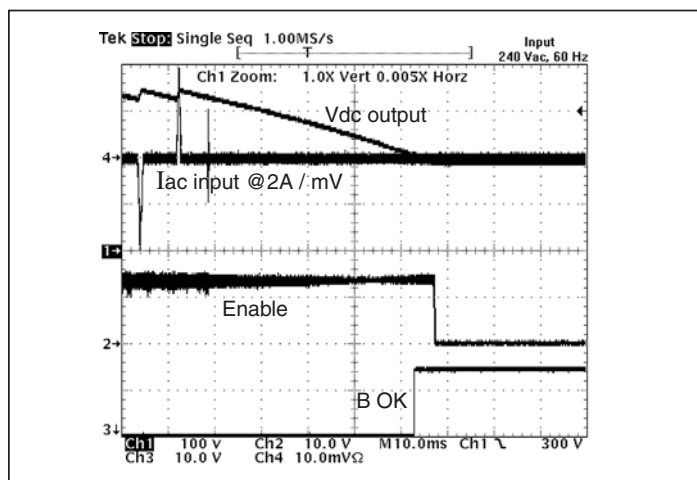

Figure 4—Power down, from 240Vac

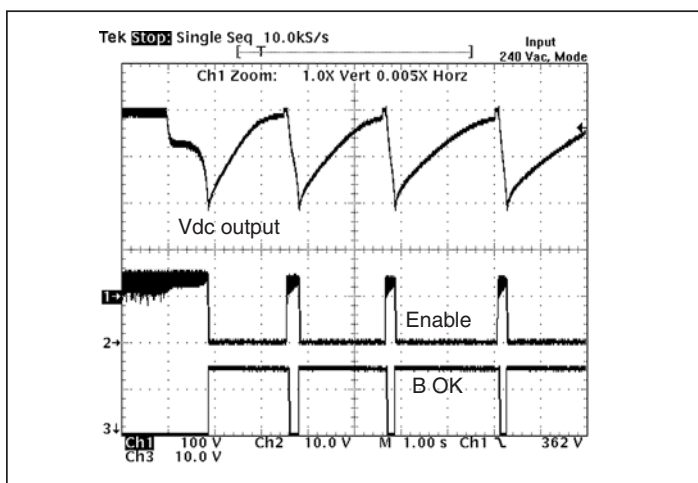

Figure 5—Output overvoltage protection 240Vac range

Application Note

The VI-ARM Autoranging Rectifier Module (ARM) provides an effective solution for the AC front end of a power supply built with Vicor DC-DC converters. This high performance power system building block satisfies a broad spectrum of requirements and agency standards.

The ARM contains all of the power switching and control circuitry necessary for autoranging rectification, inrush current limiting, and overvoltage protection. This module also provides converter enable and status functions for orderly power up/down control or sequencing. To complete the AC front end configuration, the user needs only to add holdup capacitors and a suitable input filter with transient protection.

Functional Description

The switch that bypasses the inrush limiting PTC (positive temperature coefficient) thermistor is open when power is applied, as is the switch that engages the strap for voltage doubling. (See Fig. 6). In addition, the converter modules are disabled via the Enable (EN) line, and Bus-OK (B OK) is high.

Power-Up Sequence. (See Fig. 7):

- 1.1 Upon application of input power, the output bus capacitors begin to charge. The thermistor limits the charge current, and the exponential time constant is determined by the holdup capacitor value and the thermistor cold resistance. The slope (dv/dt) of the capacitor voltage approaches zero as the capacitors become charged to the peak of the AC line voltage.

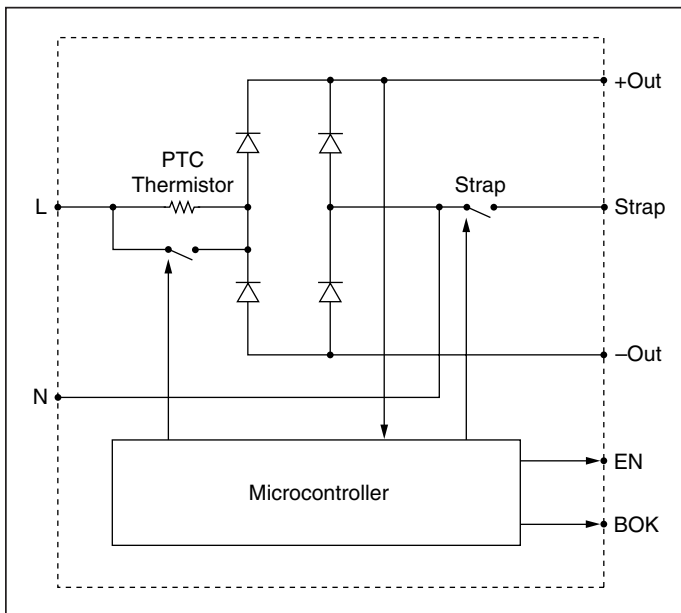

Figure 6—Functional block diagram

- 2.1 If the bus voltage is less than 200V as the slope nears zero, the voltage doubler is activated, and the bus voltage climbs exponentially to twice the peak line voltage. If the bus voltage is greater than 200V, the doubler is not activated.
- 3.1 If the bus voltage is greater than 235V as the slope approaches zero, the inrush limiting thermistor is bypassed. Below 235V, the thermistor is not bypassed.
- 4.1 The converters are enabled 50 milliseconds after the thermistor bypass switch is closed.
- 5.1 Bus-OK is asserted after an additional 50 millisecond delay to allow the converter outputs to settle within specification.

Power-Down Sequence. (See Fig. 7). When input power is turned off or fails, the following sequence occurs as the bus voltage decays:

- 1.2 Bus-OK is deasserted when the bus voltage falls below 205Vdc (Typ.).
- 2.2 The converters are disabled when the bus voltage falls below 200Vdc. If power is reapplied after the converters are disabled, the entire power-up sequence is repeated. If a momentary power interruption occurs and power is reestablished before the bus reaches the disable threshold, the power-up sequence is not repeated.

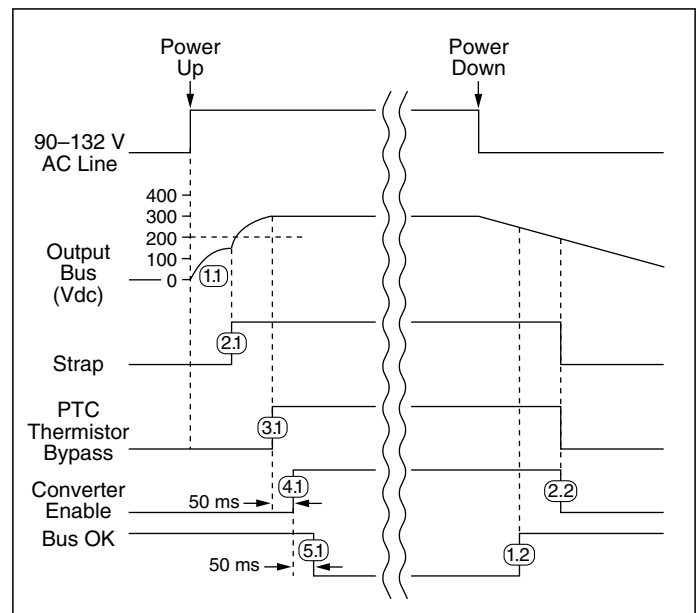

Figure 7—Timing diagram: power up/down sequence

Off-Line Power Supply Configuration

The ARM maintains the DC output bus voltage between 200 and 375Vdc over the entire universal input range, which is compatible with Vicor VI-260 series and VI-J60 series DC-DC converters, as well as next-generation 300V input Vicor converters. The ARM automatically switches to the proper rectification mode (doubled or undoubled) depending on the input voltage, eliminating the possibility of damage due to improper line connection. The ARM-1 is rated at 500W in the low range (90-132Vac input), and 750W in the high range (180-264Vac input). The ARM-2 is rated for 1000W and 1500W for the low and high input ranges respectively. Either of these modules can serve as the AC front end for any number and combination of compatible converters as long as the maximum power rating is not exceeded.

Strap (ST) Pin. In addition to input and output power pin connections, it is necessary to connect the Strap pin to the junction of the series holdup capacitors (C1, C2, Fig. 8) for proper (autoranging) operation. Varistors across the capacitors provide input transient protection. The bleeder resistors (R1, R2, Fig. 8) discharge the holdup capacitors when power is switched off.

Enable (EN) Pin. (See Fig. 9). The Enable pin must be connected to the Gate-In or PC pin of all converter modules to disable the converters during power-up. Otherwise, the converters would attempt to start while the holdup capacitors were being charged through an unbypassed thermistor, preventing the bus voltage from reaching the thermistor bypass threshold thus disabling the power supply. The Enable output (the drain of an N channel MOSFET) is internally pulled up to 15V through a 150kΩ resistor.

A signal diode should be placed close to and in series with the Gate-In pin of each converter to eliminate the possibility of control interference between converters. The Enable pin switches to the high state (15V) with respect to the negative output power pin to turn on the converters after the power-up inrush is over. The Enable function also provides input overvoltage protection for the converters by turning off the converters if the DC bus voltage exceeds 400Vdc. The thermistor bypass switch opens if this condition occurs, placing the thermistor in series with the input voltage, which reduces the bus voltage to a safe level while limiting input current in case the varistors conduct. The thermistor bypass switch also opens if a fault or overload reduces the bus voltage to less than 180Vdc.

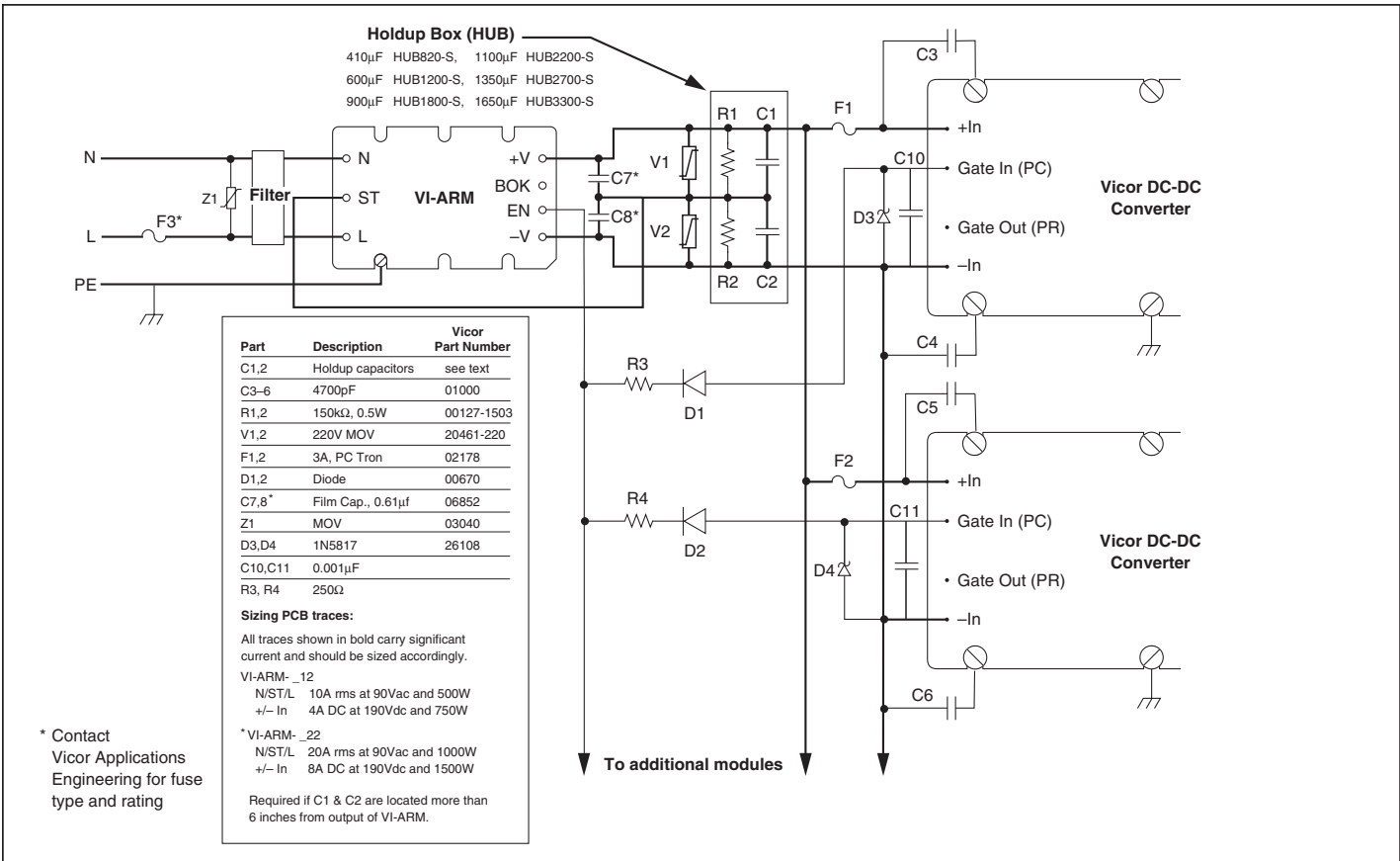

Figure 8—Converter connections

Application Note, continued

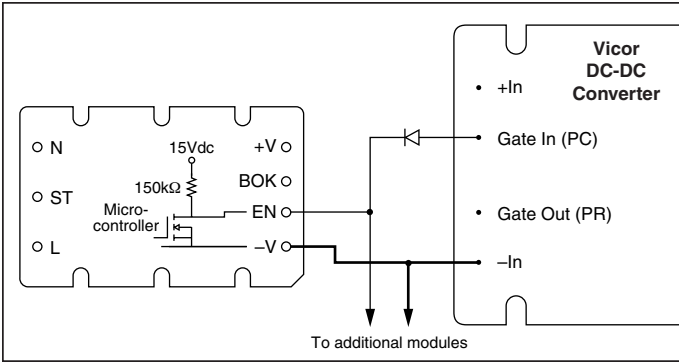

Figure 9—Enable (EN) function; See Fig. 8 for details

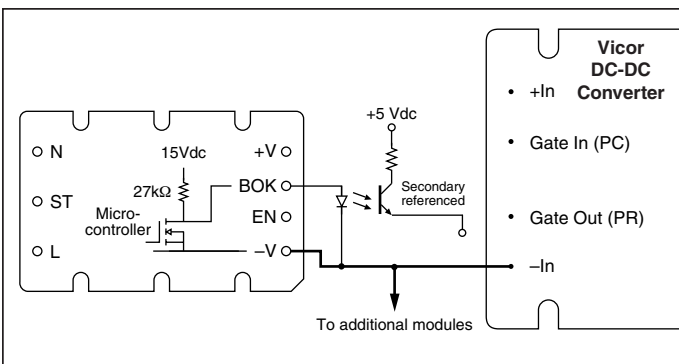

Figure 10—Bus OK (B OK) isolated power status indicator

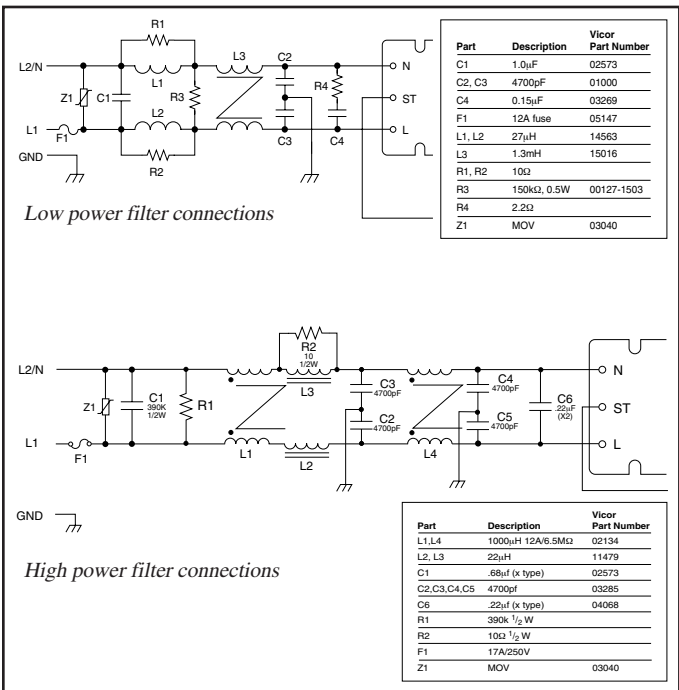

Figure 11—Filter connections

Bus-OK (B OK) Pin. (See Fig. 10). The Bus-OK pin is intended to provide early-warning power fail information and is also referenced to the negative output pin.

Caution: There is no input to output isolation in the ARM. It is necessary to monitor Bus-OK via an optoisolator if it is to be used on the secondary (output) side of the converters. A line isolation transformer should be used when performing scope measurements. Scope probes should never be applied simultaneously to the input and output as this will destroy the unit.

Filter. Two input filter recommendations are shown for low power VI-ARM-1 and high power VI-ARM-2 (See Fig. 11). Both filter configurations provide sufficient common mode and differential mode insertion loss in the frequency range between 100kHz and 30MHz to comply with the Level B conducted emissions limit.

Hold-up Capacitors. Hold-up capacitor values should be determined according to output bus voltage ripple, power fail hold-up time, and ride-through time. (See Fig. 12). Many applications require the power supply to maintain output regulation during a momentary power failure of specified duration, i.e., the converters must hold-up or ride-through such an event while maintaining undisturbed output voltage regulation. Similarly, many of these same systems require notification of an impending power failure in order to allow time to perform an orderly shutdown.

The energy stored on a capacitor which has been charged to voltage V is:

$$\epsilon = 1/2(CV^2) \tag{1}$$

Where: ϵ = stored energy
C = capacitance
V = voltage across the capacitor

Energy is given up by the capacitors as they are discharged by the converters. The energy expended (the power-time product) is:

$$\epsilon = P\Delta t = C(V_1^2 - V_2^2) / 2 \tag{2}$$

Where: P = operating power
 Δt = discharge interval
 V_1 = capacitor voltage at the beginning of Δt
 V_2 = capacitor voltage at the end of Δt

Rearranging equation 2 to solve for the required capacitance:

$$C = 2P\Delta t / (V_1^2 - V_2^2) \tag{3}$$

Application Note, continued

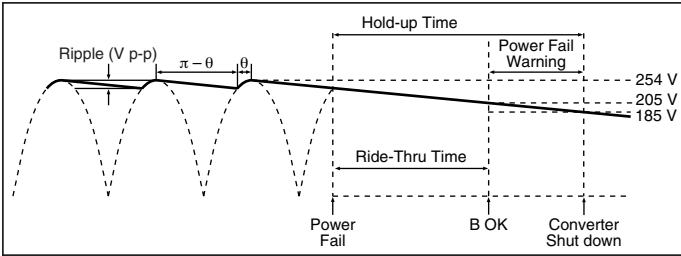

Figure 12—Hold-up time

The holdup time (Δt) is defined as the interval between power fail warning (B OK) and converter shutdown (EN) as illustrated in Fig. 12. The Bus-OK and Enable thresholds are 205V and 185V, respectively. A simplified relationship between hold-up time, operating power, and bus capacitance is obtained by inserting these constants:

$$C = 2P\Delta t / (205^2 - 185^2)$$

$$C = 2P\Delta t / (7,800)$$

It should be noted that the series combination ($C1, C2$, Fig. 8) requires each capacitor to be twice the calculated value, but the required voltage rating is reduced to 200V.

Allowable ripple voltage on the bus (or ripple current in the capacitors) may define the capacitance requirement. Consideration should be given to converter ripple rejection and resulting output ripple voltage. The ripple rejection (R) of many Vicor converters is specified as a function of the input/output voltage ratio:

$$R = 30 + 20\log(V_{in} / V_{out}) \tag{4}$$

For example, a converter whose output is 15V and nominal input is 300V will provide 56dB ripple rejection, i.e., 10V p-p of input ripple will produce 15mV p-p of output ripple. (See Fig. 16) Equation 3 is again used to determine the required capacitance. In this case, V_1 and V_2 are the instantaneous values of bus voltage at the peaks and valleys (see Fig. 12) of the ripple, respectively. The capacitors must hold up the bus voltage for the time interval (Δt) between peaks of the rectified line as given by:

$$\Delta t = (\pi - \theta) / 2\pi f \tag{5}$$

Where: f = line frequency
 θ = rectifier conduction angle

The approximate conduction angle is given by:

$$\theta = \cos^{-1} V_2 / V_1 \tag{6}$$

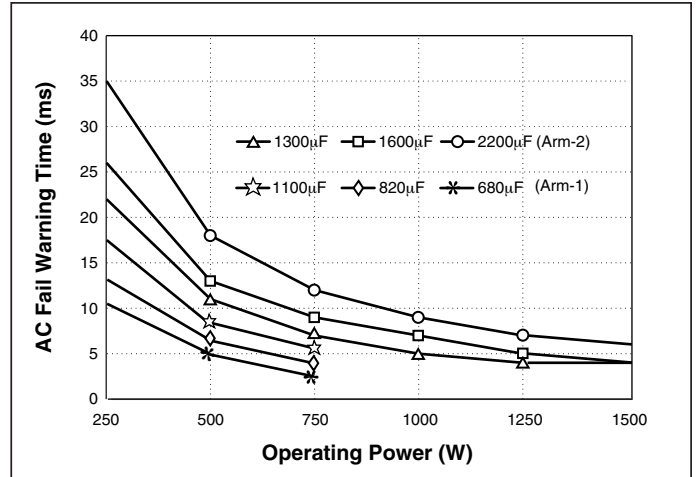

Figure 13—Hold-up time vs. operating power and total bus capacitance, series combination of $C1, C2$ (Fig. 8)

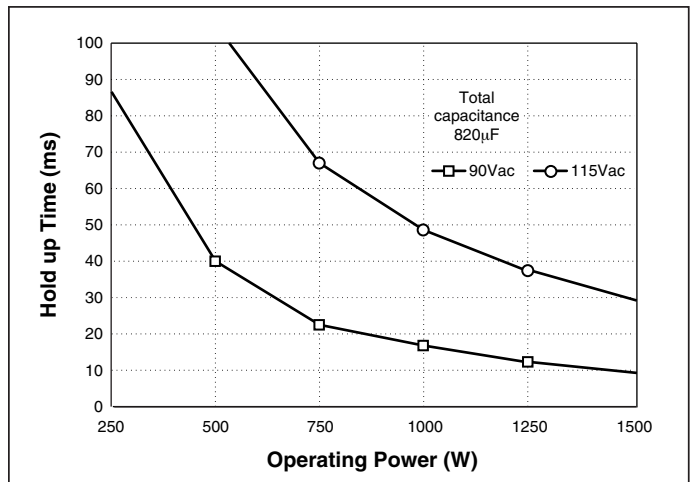

Figure 14—Ride-through time vs. operating power

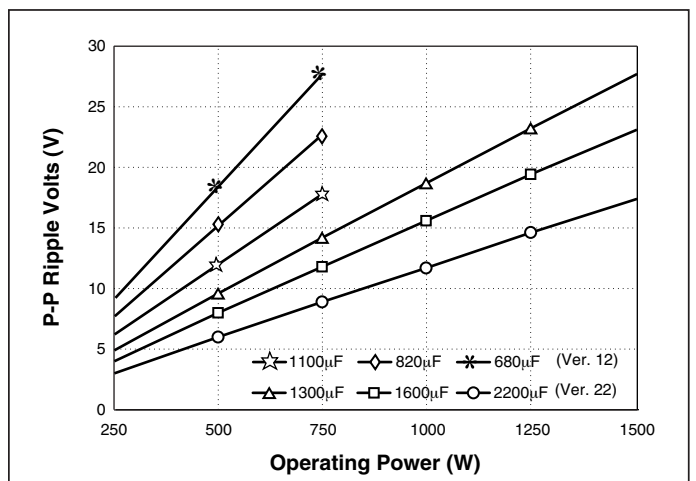

Figure 15—Ripple voltage vs. operating power and bus capacitance, series combination of $C1, C2$ (see Fig. 8)

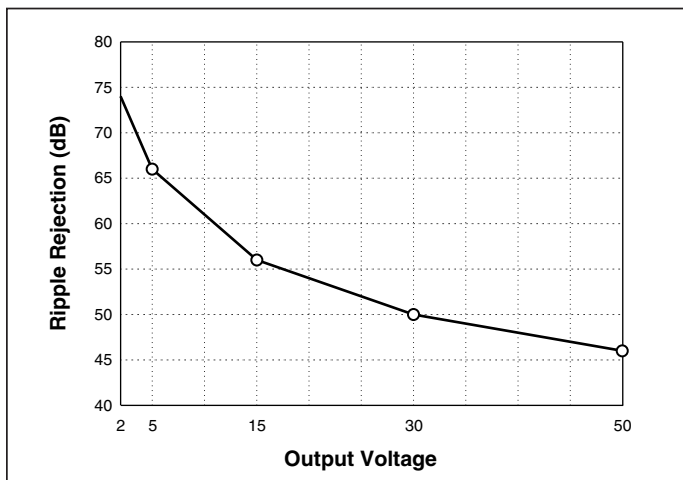

Figure 16—Converter ripple rejection vs. output voltage

Another consideration in hold-up capacitor selection is their ripple current rating. The capacitors' rating must be higher than the maximum operating ripple current. The approximate operating ripple current (rms) is given by:

$$I_{rms} = 2P/V_{ac} \quad (7)$$

Where: P = operating power level
 Vac = operating line voltage

Calculated values of bus capacitance for various hold-up time, ride-through time, and ripple voltage requirements are given as a function of operating power level in Figures 13, 14, and 15, respectively.

Example

In this example, the output required at the point of load is 12Vdc at 320 Watts. Therefore, the output power from the ARM would be 375 Watts (assuming a converter efficiency of 85%). The desired hold-up time is 9 ms over an input range of 90 to 264Vac.

Determining Required Hold-up Capacitance. Fig. 13 is used to determine hold-up capacitance for a given hold-up time and power level, and shows that the total bus capacitance must be at least 820µF. Since two capacitors are used in series, each capacitor must be at least 1,640µF. Note that hold-up time is not dependent on line voltage.

Determining Ride-through Time. Figure 14 illustrates ride-through time as a function of line voltage and output power, and shows that at a nominal line of 115Vac, ride-through would be 68 ms. Ride-through time is a function of line voltage.

Determining Ripple Voltage on the Hold-up Capacitors.

Fig. 15 is used to determine ripple voltage as a function of operating power and bus capacitance, and shows that the ripple voltage across the hold-up capacitors will be 12Vac.

Determining the Ripple on the Output of the DC-DC Converter.

Fig. 16 is used to determine the ripple rejection of the DC-DC converter and indicates a ripple rejection of approximately 60 dB for a 12 Volt output. If the ripple on the bus voltage is 12Vac and the ripple rejection of the converter is 60 dB, the output ripple of the converter due to ripple on its input (primarily 120Hz) will be 12 mV p-p. Note that 2nd Generation converters have greater ripple rejection than either VI-200s or VI-J00s.

For more information about designing an autoranging AC input power supply using the ARM and Vicor DC-DC converter modules, contact Vicor Applications Engineering at the nearest Vicor Technical Support Center (see back cover), or send an E-mail to apps@vicr.com.

• • •

Mechanical Drawings

MODULE OUTLINE

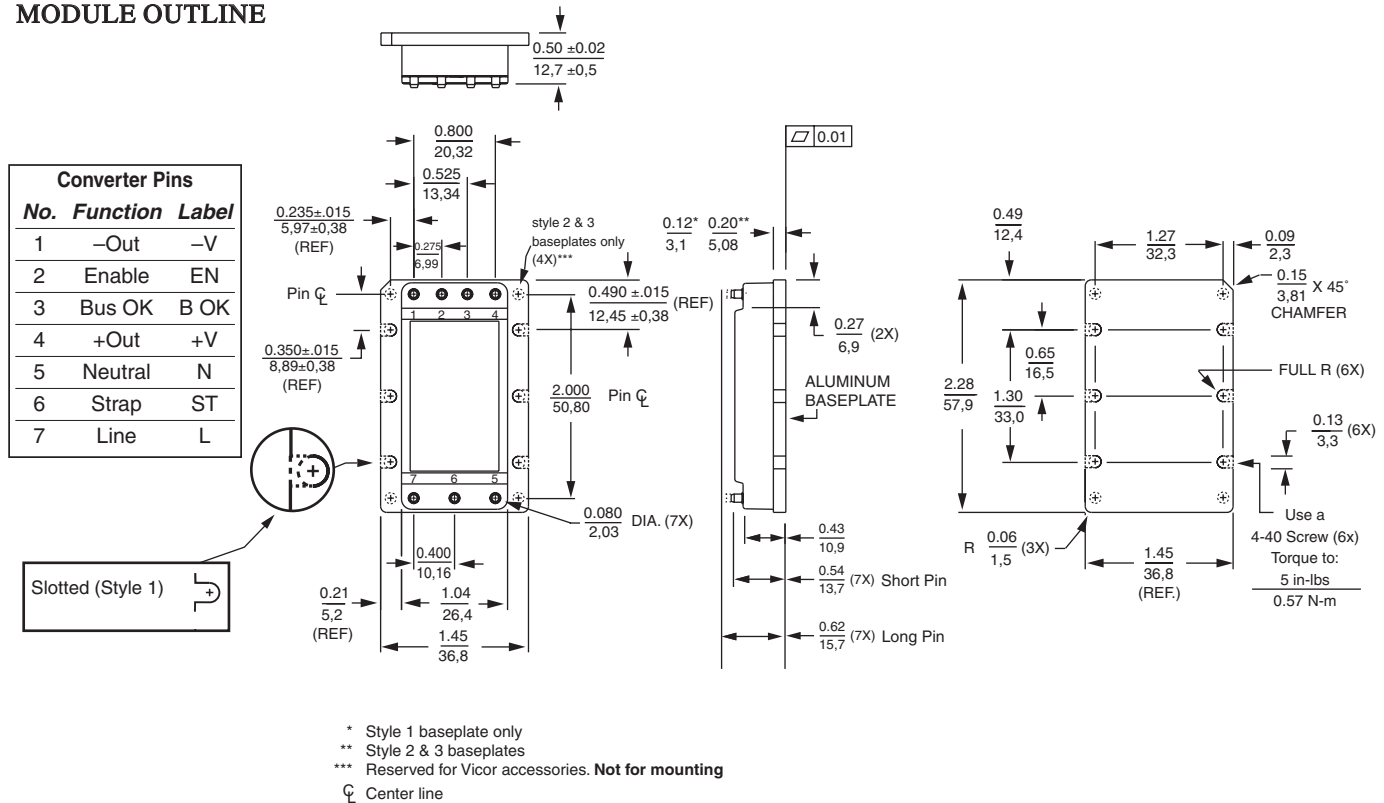

PCB MOUNTING SPECIFICATIONS

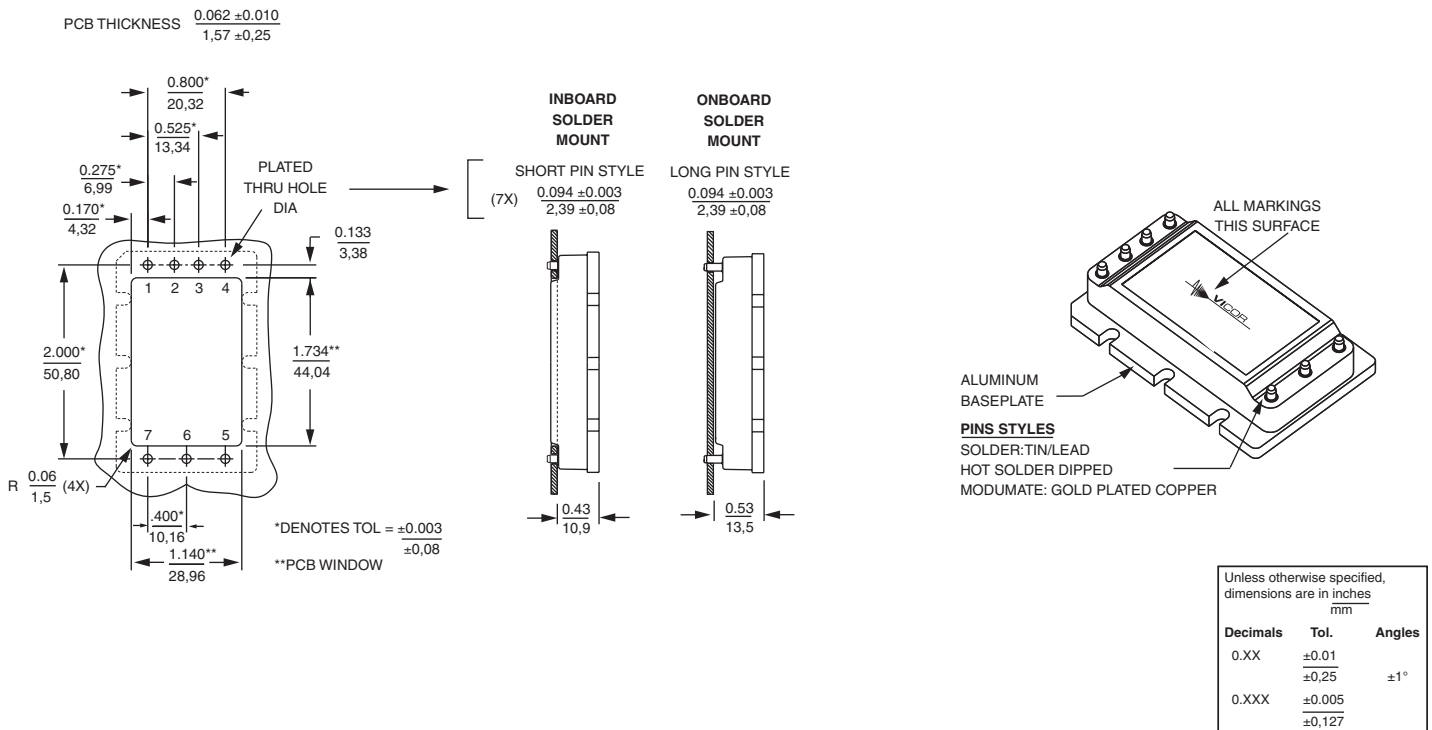

Vicor's comprehensive line of power solutions includes high density AC-DC and DC-DC modules and accessory components, fully configurable AC-DC and DC-DC power supplies, and complete custom power systems.

Information furnished by Vicor is believed to be accurate and reliable. However, no responsibility is assumed by Vicor for its use. Vicor components are not designed to be used in applications, such as life support systems, wherein a failure or malfunction could result in injury or death. All sales are subject to Vicor's Terms and Conditions of Sale, which are available upon request.

Specifications are subject to change without notice.



*Component Solutions
for Your Power System*

Vicor Corporation
25 Frontage Road
Andover, MA, USA 01810
Tel: 800-735-6200
Fax: 978-475-6715

Email

Vicor Express: vicorexp@vicr.com
Technical Support: apps@vicr.com